

Dowel and Tenon Cutters

U.S. Des. Pat. No. D547,155

 **Caution:** Always wear safety glasses when using this tool. Blades are extremely sharp. Handle with care.

Traditionally made with a steel blade fixed to a wooden body, this type of tool has been around for hundreds of years. Often user built, it is favored for making dowels or tenons without a lathe.

Veritas® Dowel and Tenon Cutters are available in three diameters ($3/8"$, $7/16"$ and $1/2"$) and come with a high-carbon steel blade fixed in a cast zinc body. These cutters can be used two ways. Using them like a hand-held pencil sharpener, you can put accurate tenons on the tips of turnings or on rustic furniture components. The cutters can also be used with a power feed to make accurate dowelling. Works equally well in soft, green or hard woods.

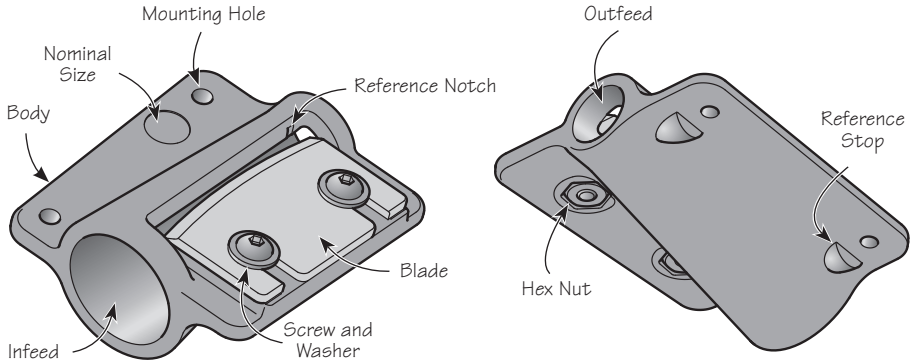

Figure 1: Dowel and tenon cutter components.

A Note About Drill Bits: Since tenons and dowels are normally made to fit into a mating hole, be aware that the diameters of some types of drill bits are often inaccurate or deliberately different from the nominal size.

Making Dowel

The cutters can be used to make precisely sized dowel in any wood. The sharper the blade, the less final smoothing and sanding will be required; see *Sharpening* below.

Dowel is best made by driving the blank with an electric drill. A heavy-duty rechargeable drill is generally adequate, but a corded drill (min. 500 watts) is recommended. Optional square sockets are available in two sizes ($1/2"$ and $5/8"$). Each of these may be fitted with an adapter so it may be chucked in an electric drill to drive a dowel blank.

Rip blanks into strips with a square cross section $\frac{1}{16}$ " oversize. Careful preparation of stock is important, as the resultant dowel will not be any straighter than the blank. The blank should be straight grained and consistent in size and shape down its length. The end that is to be introduced to the infeed should be cut clean and square. The chart at right shows what socket to use for a given dowel diameter.

Square Socket	Dowel Size (diameter)
$\frac{5}{8}$ "	$\frac{1}{2}$ "
$\frac{1}{2}$ "	$\frac{7}{16}$ ", $\frac{3}{8}$ "

Test fit the blank into the appropriate socket, and trim if required.

With the socket chucked in your drill, place one end of the blank into it and the opposite end into the infeed. (See **Figures 2 and 3.**) Take care to align the workpiece as closely as possible with the axis of the cutter. Start with moderate feed pressure and slow speed. Experiment with these two variables to find what works best for each combination of dowel material and diameter.

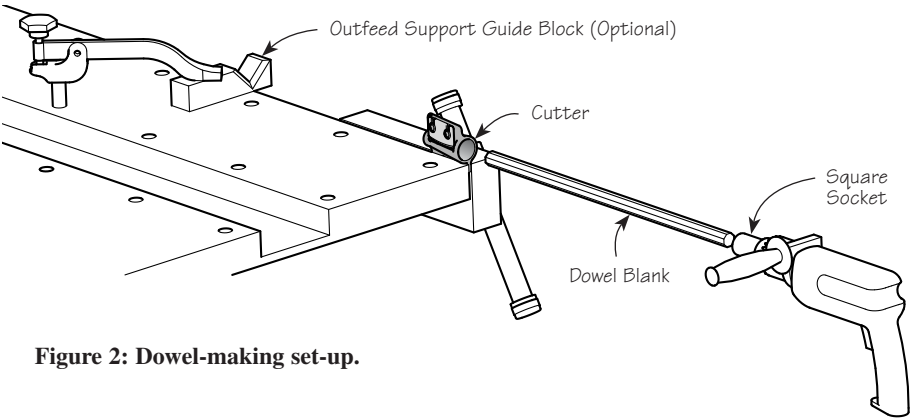

Figure 2: Dowel-making set-up.

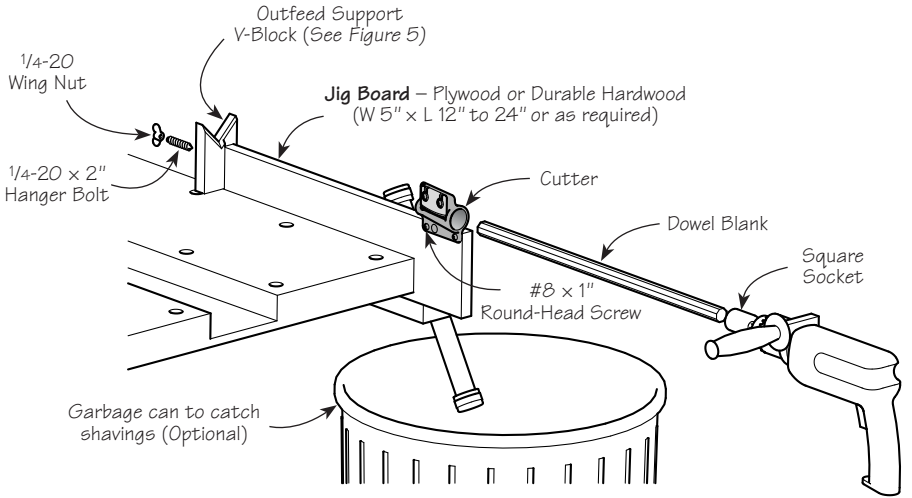

Figure 3: Alternative dowel-making set-up.

Depending on the diameter and length of the dowel being made, there may be a tendency for it to whip. This can affect the accuracy and finish of the dowel and, in extreme cases, cause the dowel to break. You may need outfeed and infeed support for dowel longer than 12". Shop-made guides mounted to your workbench work fine as dowel supports. Soft wood is recommended in order to reduce the chance of marring your dowel. Alternatively, you may use a hard material with a soft lining (such as corrugated cardboard). **Figures 4 and 5** provide guide block examples that may be altered to suit your needs. Feel free to experiment with different types of guides. You may find that something as simple as a cardboard box with a couple of holes through it works well.

⚠ Caution: When making oversize dowel in hardwood, the body of the cutter may start to get warm. Blade position and cutting speed may need to be adjusted.

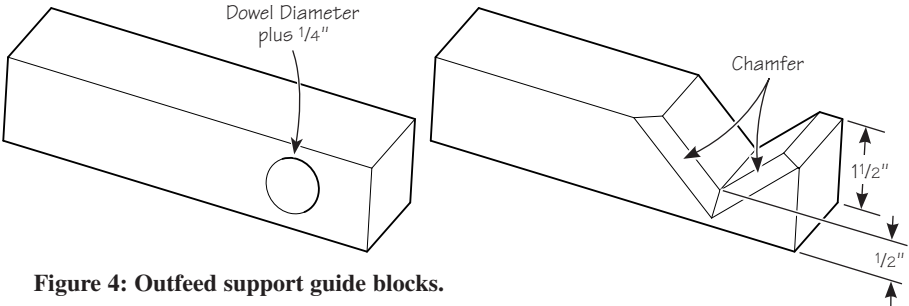

Figure 4: Outfeed support guide blocks.

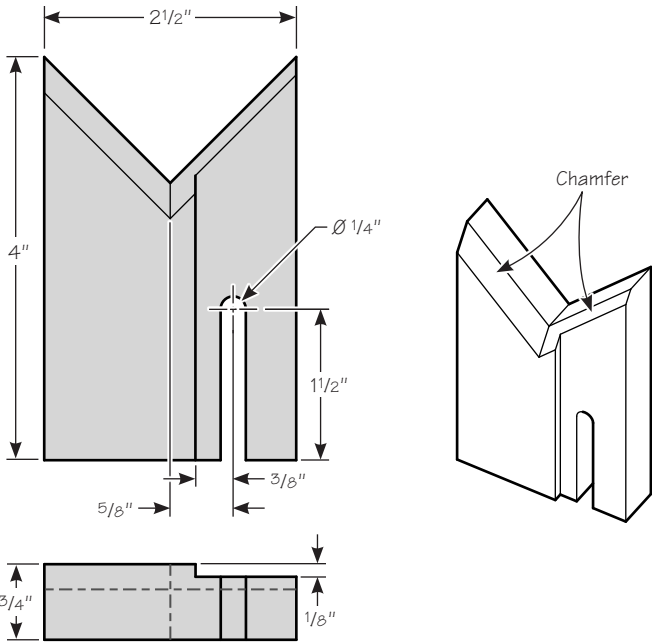

Figure 5: Outfeed support V-block (adjustable).

Tenons

The cutter can be used to create an accurate, repeatable, round tenon on the end of a workpiece. As shown in **Figure 6**, the tenon is straight and blends with the workpiece in a gentle curve that should require little or no further attention.



Figure 6: Typical straight tenon.

The cutter works much like a pencil sharpener. You need only press the workpiece into the infeed and rotate either the tool or workpiece relative to the other. **Figures 7 to 10** show several different ways of holding the workpiece and tool.

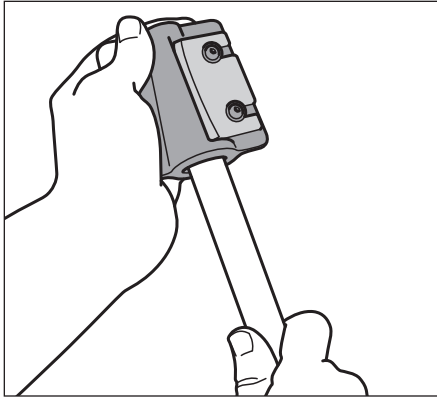

Figure 7: Hand position.

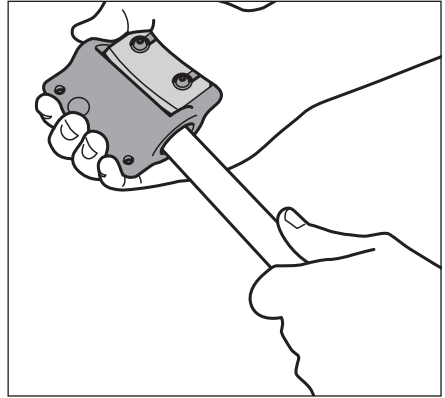

Figure 8: Alternative hand position.

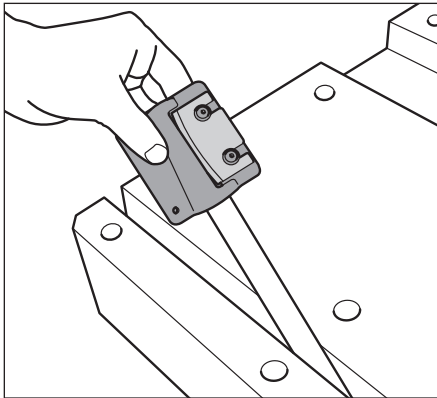

Figure 9: Using a vise, turning the cutter.

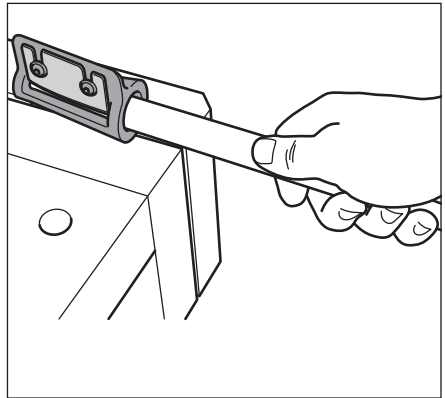

Figure 10: Using a vise, turning the workpiece.

You can clamp the cutter and turn the workpiece, or vice versa. Also, you can hold the workpiece in one hand and the cutter in the other. It's all a matter of personal preference.

In most instances, the tenon produced should be concentric with the rest of the workpiece. To help achieve a properly aligned tenon, keep the workpiece centered in the infeed, as shown in **Figure 11**.

Adjustment

⚠ Caution: Be aware that the blade is sharp; careless handling can result in serious injury.

Since one blade setting may not yield the same diameter from one species of wood to another, you may need to adjust the blade accordingly. Always make a test tenon with a scrap piece of wood of the same material as your workpiece, then check the diameter of the tenon by test fitting in a hole of the same size.

The blade is retained with two screws. A 1/8" hex key is provided to loosen or remove the screws for blade adjustment or removal. (Be aware that the hex nuts are not captured and will fall out when the screws are removed.) The blade bed has index lines to help judge the blade's position and relative movement. For typical use, set the blade so the cutting edge is positioned as shown in **Figure 12**. The blade should be closest to the back of the throat at a point that is no more than two-thirds of the way from the infeed end of the bore.

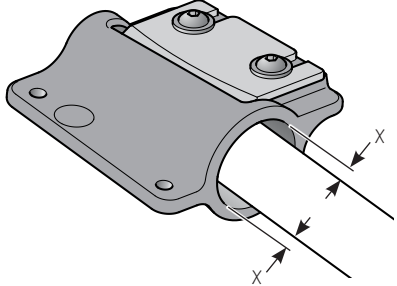

Figure 11: Workpiece alignment.

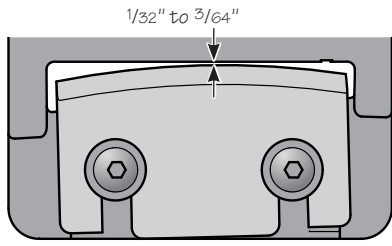

Figure 12: Blade placement.

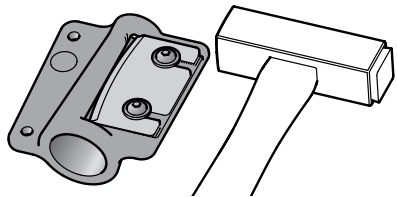

Figure 13: Blade adjustment.

If the tenon is too large or the blade stops cutting before a tenon is formed, ease the tension of the outfeed screw and tap the blade, as shown in **Figure 13**, to decrease workpiece diameter. Retighten the screws.

If the tenon or dowel is too small, loosen both screws and withdraw the blade. Partially retighten the screws, then continue adjustment with a small hammer as above.

For optimum surface finish on the tenon, orient the blade so that the cut ceases before contacting the outfeed corner of the blade. However, if surface finish and diameter are acceptable, you need not be overly concerned about how the blade is set.

If shavings clog the mouth, start with the blade further out than shown in **Figure 12**. **It may be necessary to skew the blade to achieve the desired diameter without clogging.**

Sharpening

The blade is supplied with a 30° bevel ground in a 7" radius. As supplied, the cutting edge is adequate for rough work in most woods; however, accuracy and surface finish will be improved with additional sharpening.

Note: For reference during future sharpenings, you may want to make a simple radius gauge from a small piece of sheet material such as 1/8" plywood or plastic laminate. Trace the cutting edge onto the gauge material or use a compass to draw an arc with a 7" radius. Cut to the resultant line.

The easiest way to sharpen this blade, by far, is with a 1" belt sander/grinder (e.g., 68Z75.01, available from Lee Valley Tools). For quickest results, start with 320x and finish with 1200x abrasive. Although 1200x is the approximate equivalent to only a 2000x stone, when used under power, it will provide a finish comparable to working by hand on a 4000x stone.

If you do not have access to a belt grinder, start by lapping the back of the blade to a fine polish, as shown in **Figure 14**. Use a series of stones, starting with 800x to 1000x and finishing with at least 4000x. (This job will progress fastest if you use as many intermediate steps as possible.) Next, hone a 1° to 2° micro-bevel, starting with a 1000x stone. Hold the blade as shown in **Figure 15** and hone with a back-and-forth sweeping motion.

Although the exact radius of the cutting edge is not critical, check it occasionally with your radius gauge to maintain it as near as possible to 7". Repeat with a 4000x stone. If desired, you may finish with a 6000x or 8000x stone. By this time, a small wire edge or burr will have formed from working the bevel. When you reach the finest abrasive, remove the wire edge by alternately lapping the back and honing the bevel.

If the blade ever requires regrinding, establish the bevel between 25° and 30°. Hone at 30° to 32°, as described above.

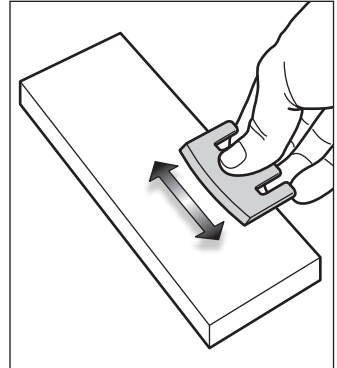

Figure 14: Lapping.

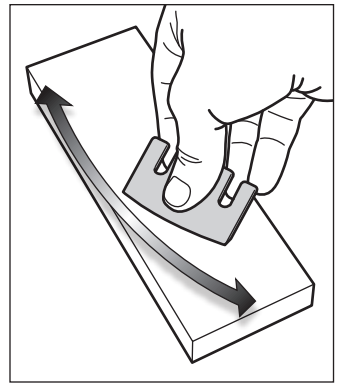

Figure 15: Honing.

Care and Maintenance

The cast zinc body of the dowel and tenon cutter is durable and corrosion resistant; however, the high-carbon steel blade may rust if exposed to moisture. If storage conditions are damp or humid, the cutter should be wrapped in a cloth or stored in a plane sack. This precaution will also guard against dings and scratches. Periodically, or following exposure to moisture, take the tool apart to clean it. Remove the blade from the body and clean all parts using a cloth dampened with a dab of light machine or mineral oil.

Accessories

- 05J60.20** Replacement Curved HCS Blade
- 05J60.30** Socket Adapter
- 05J60.31** 1/2" Socket (for 3/8" and 7/16" dowel)
- 05J60.33** 5/8" Socket (for 1/2" dowel)
- 05J60.39** Socket/Adapter, set of 3